



ISO9001:2000认证企业  
CE 认证企业  
国家级高新技术企业

# 580-33000KN Injection Molding Machine



**宁波海星机械制造有限公司**  
NINGBO HAIXING MACHINERY MANUFACTURING CO.,LTD.



海星公司总部地址：宁波高新区梅景路17号  
ADD: MEIJING ROAD NO.17 HI-TECH PARK NINGBO P.R.CHINA  
海星公司震浦地址：宁波市北仑区霞浦万泉河路98号  
ADD: NO.98 WANQUANHE ROAD XIAPU BEILUN ZHEJIANG PROVINCE P.R.CHINA  
总机 (TEL) : +86-574-8836 8836 8836 9335  
电话 (TEL) : +86-574-8836 9515 8848 7496  
传真 (FAX) : +86-574-8836 8262  
售后服务电话: +86-574-88487295 邮编 (P.C.) : 315103  
[Http://www.china-haixing.com](http://www.china-haixing.com)

International Business Department  
TEL:+86-574-8835 1898  
FAX:+86-574-8848 7616  
E-mail:sales@china-haixing.com

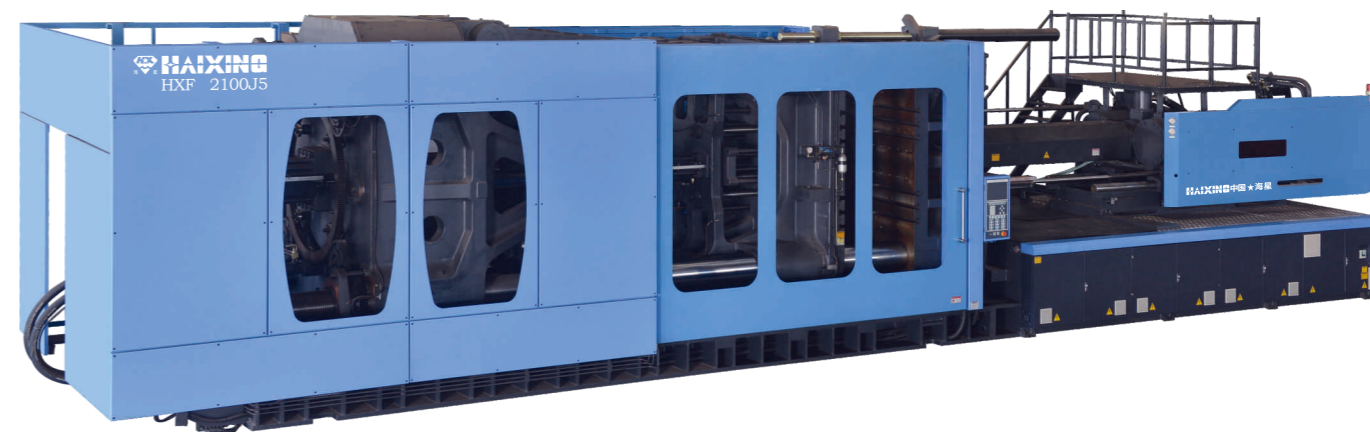

## 超卓无限 引领中国机械制造业新途

### 公司介绍

### INTRODUCTION

宁波海星机械制造有限公司位于浙江省宁波市高新区。公司拥有九万多平方米的国际标准厂房及批量大型加工中心和大批先进的加工设备，海星牌注塑机有20多种规格。从58T到3300T不等，海星牌注塑机配件配备世界一流的液压、电器及控制系统，引进欧洲风格的设计理念，通过严格的检测、装配、调试，为客户提供中国大陆一流水准的产品与服务。

宁波海星机械制造有限公司是中国注塑机行业著名企业之一，始终保持适中生产规模，力求稳步发展，努力做好每一台海星牌注塑机。公司总经理陈兴良先生自一九七二年开始学习、研究、设计、生产注塑机，九十年代初曾赴美三年，是业内资深的工程师。海星塑机借鉴国内外优秀技术结合自身经验的完美力作。

海星公司凭其优秀的品质、专业的服务，赢得了广大客户的信任。公司在中国的北京、天津、青岛、苏州、上海、余姚、温州、东莞、深圳等地建立了完善的销售及网络。公司努力开拓国际市场，海星牌注塑机目前已被伊朗、阿根廷、澳大利亚、巴西、哥伦比亚、哥斯达黎加、加纳、德国、希腊、菲律宾、泰国、美国等七十多个国家的客户所使用。海星公司正逐步建立起以海星品牌为核心的面向国内国际市场的营销体系。

海星凭借其强大的研发设计创新能力，不断地为客户提供适应不同产品及要求的个性化机器。优秀的品质、专业的服务、优良的技术保证，海星公司愿与世界各地的客户携手共创美好未来。



海星公司外景 Haixing company outdoor scene



海星公司霞浦厂区外景 Haixing company xiapu factory outdoor scene



装配车间 Assembly Workshop



装配车间 Assembly Workshop



装配车间 Assembly Workshop

Ningbo Haixing Machinery Manufacturing Co.,Ltd is located in Ningbo Hi-Tech park, Zhejiang province. Our company covers an area of more than 90000 square meters factory with many CNC machine centres. We specialized in producing over 20 types injection molding machines with clamping force between 58 to 3300 metric tons. Haixing injection machines equipped with famous brand hydraulic, electric components and control system. Our company brings in European design, through strict testing, assembling, commissioning, providing the first class production and service for customer.

Ningbo Haixing Machinery Manufacturing Co.,Ltd is one of the most famous companies in the plastic machinery industry in China. Haixing company keeps the moderate scale of production and makes concerted effort to fulfill every machine. The manager Chen xingliang is a professional engineer, he devoted himself to injection molding machine from 1972. In the 1990's, he spent 3 years in the USA for the study, research, design and produce injection molding machines. Haixing machine is the perfect combination of its own extraordinary experience with foreign advanced technology.

Ningbo Haixing Machinery Manufacturing Co.,Ltd resorts to its essential professional service to earn the customer's trust. Our company has established satisfactory sales and service network in Beijing, Tianjin, Qingdao, Suzhou, Shanghai, Yuyao, Wenzhou, Dongguan, Shenzhen and so on. In addition, Haixing brand injection molding machines have been exported to over 70 countries such as: Iran, Argentina, Australia, Brazil, Colombia, Costa Rica, Ghana, Germany, Greece, Holland, India, Indonesia, Israel, Italy, Japan, Jordan, Malaysia, Mexico, Norway, Pakistan, Philippines, Poland, Portugal, Russia, Saudi Arabia, Spain, South Africa, Sudan, Suriname, Thailand, Turkey, USA, Vietnam, Venezuela, Zambia, more and more agent begin to sell Haixing machine. Haixing company is gradually building up a centralized marketing system all over the world.

Ningbo Haixing Machinery Manufacturing Co.,Ltd depends on powerful creative ability to provide personalized machines that meet different requirements. Good quality, professional service as well as exquisite technology for current and prospective customers worldwide.



CNC加工中心 CNC Machines



CNC加工中心 CNC Machines



三坐标检测仪  
Three Coordinates Measuring Machine

HXF-J5 Servo Energy-saving Injection Molding Machines

# HXF-J5系列伺服节能注塑机

伺服节能注塑机，输出功率随负荷变化而变化，不存在多余的能量浪费。冷却极端电机不工作，耗电为0。伺服节能注塑机相比传统注塑机可节能30%-80%，给您带来真正的省电享受，经济效益显著。

Servo Energy-saving Injection Molding Machines: there is No Extra Energy Consumption Due To Output Volume Changes According To Load. In The Phase Of Holding Pressure, servo Motor Lowers Rotate And Consumes A Little Of Energy. Motor doesn't Work And Consumes No Energy. servo Energy-saving Injection Molding Machines Will Save30%-80% Energy And Bring You Prominent Economic.



## 注射部件

1. 优化设计精密塑化系统
2. 双缸平衡注射系统
3. 多级压力、多级速度射胶调整
4. 背压调节装置

## INJECTION UNIT

1. Precise screw system with optimized design
2. Double-cylinder balanced injection system
3. Multi-stage pressure and speed injection
4. Back pressure adjustment device

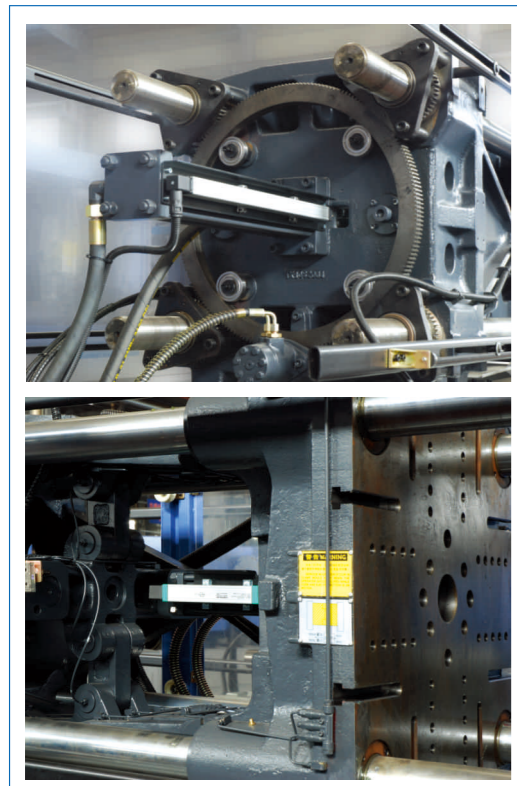

## 合模部件

1. 联体箱式模板设计
2. 五支点双曲肘锁模机构
3. 液压马达驱动齿轮调模
4. 精密、低压、快速调模设计
5. 低压模保功能

## CLAMPING UNIT

1. Box mould platen design
2. 5 Points vertical double toggle mechanism
3. hydraulic motor drive the gear to adjust the mould thickness.
4. Precision, low pressure and fast mould adjustment
5. Low-pressure mold protection

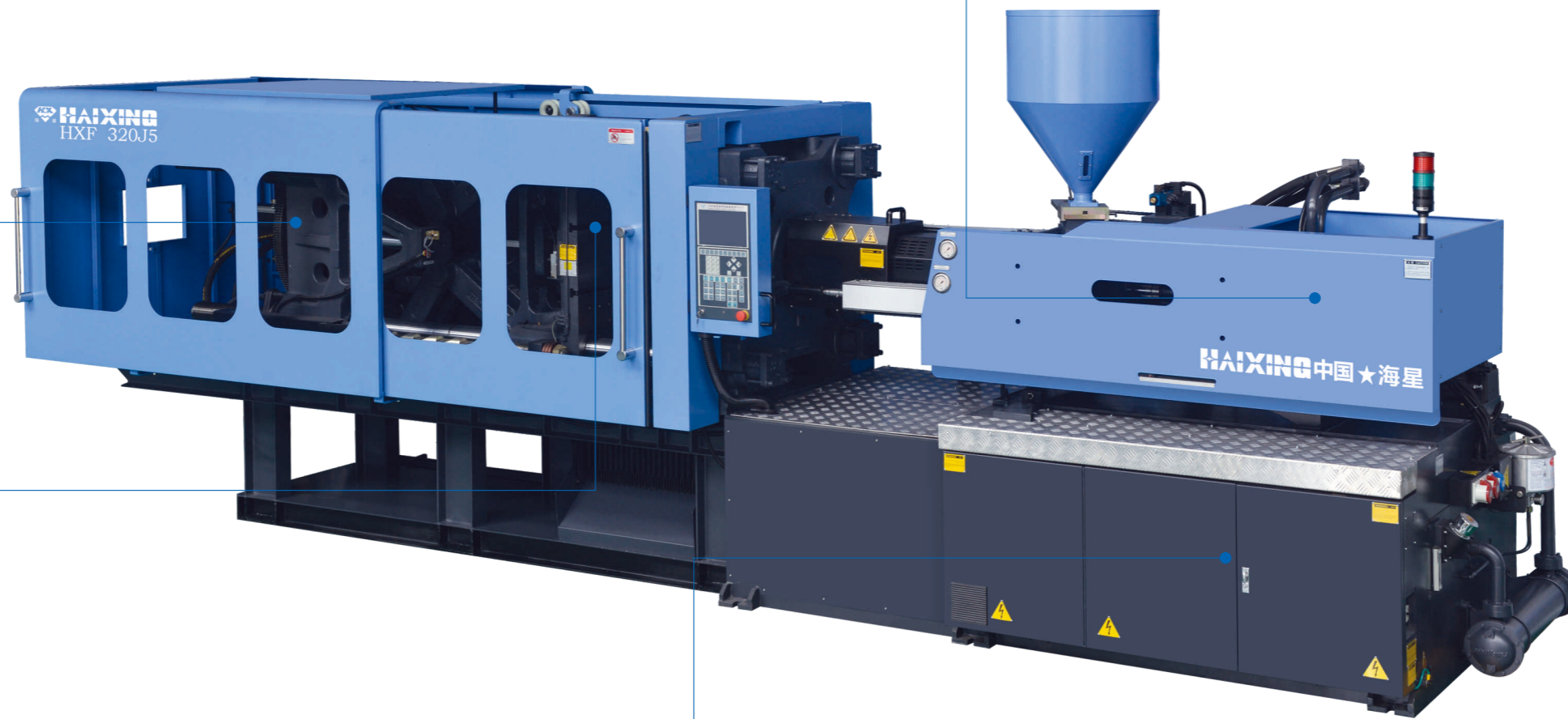

## 液压部件

1. 高响应油路设计
2. 压力流量比例控制
3. 世界名牌液压元件

## HYDRAULIC SYSTEM

1. High-response hydraulic system design
2. Pressure and flow proportional control
3. World famous brand hydraulic components

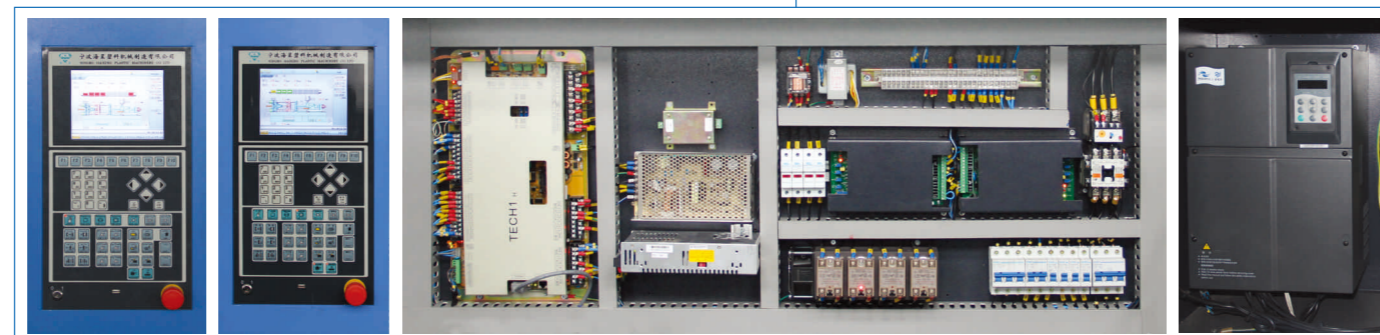

## 控制部分

1. 进口名牌电器元件
2. 大屏幕液晶显示
3. 机器运行动态监测
4. 200组大容量模具数据存储
5. 灵敏故障显示报警功能
6. 注射、合模、托模采用电子尺精确控制

## CONTROL UNIT

1. World famous brand electric components
2. Large screen LCD
3. Dynamic monitor of machine operation
4. 200 moulding data system
5. Sensitive errors indication and alarm function
6. Liner displacement transducer controls injection, clamping, ejection.

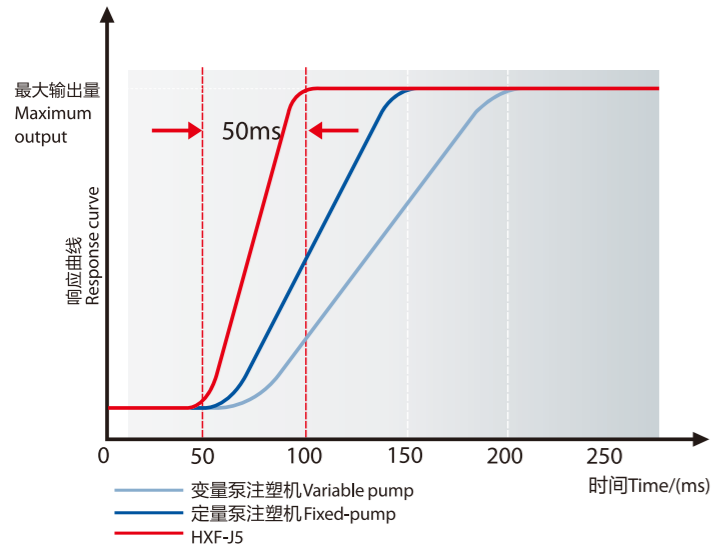

### 伺服电机的高响应特性 Quick response of servo motor

由于采用高响应伺服电机与内啮合齿轮泵动力系统，注塑机达到最大输出量仅需0.05s，相比传统液压注塑机响应速度明显加快，有效缩短周期，提高生产效率。

The response time of the drive system is very fast. It requires only 0.05s to reach the maximum power output. Cycle time is substantially shortened comparing with the plastic parts production by traditional hydraulic injection molding machines. The efficiency is improved significantly.

注射精度比较 Comparison of injection precision

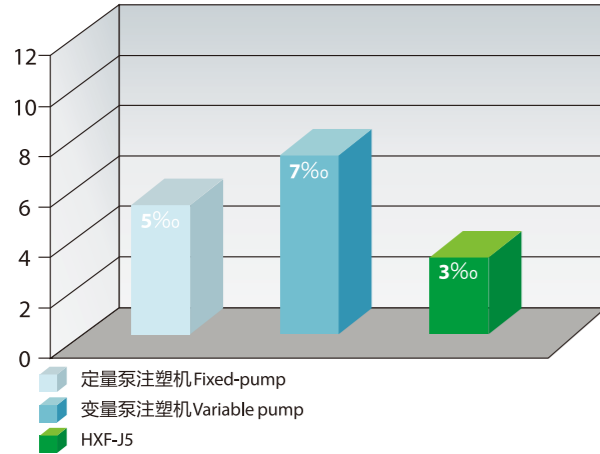

### 注射重复精度比较 Precision tolerance comparison

伺服电机的精密特性与内啮合齿轮泵的精密特性叠加，并通过高灵敏度的压力反馈装置形成闭环，注射重复精度可达3‰，相比传统液压机表现出更强的注射稳定性，成型产品的合格率大幅提高。

(Thin wall parts)  
The precision of processing tolerances to produce the plastic parts will be greatly improved by using the energy-saving HXF-J5, instead of using traditional hydraulic machines using either a fixed or variable pump. The optimized rate of repeated qualified parts is around 40-130%

### 伺服机能曲线 CURVE OF ENERGY-SAVING MACHINES

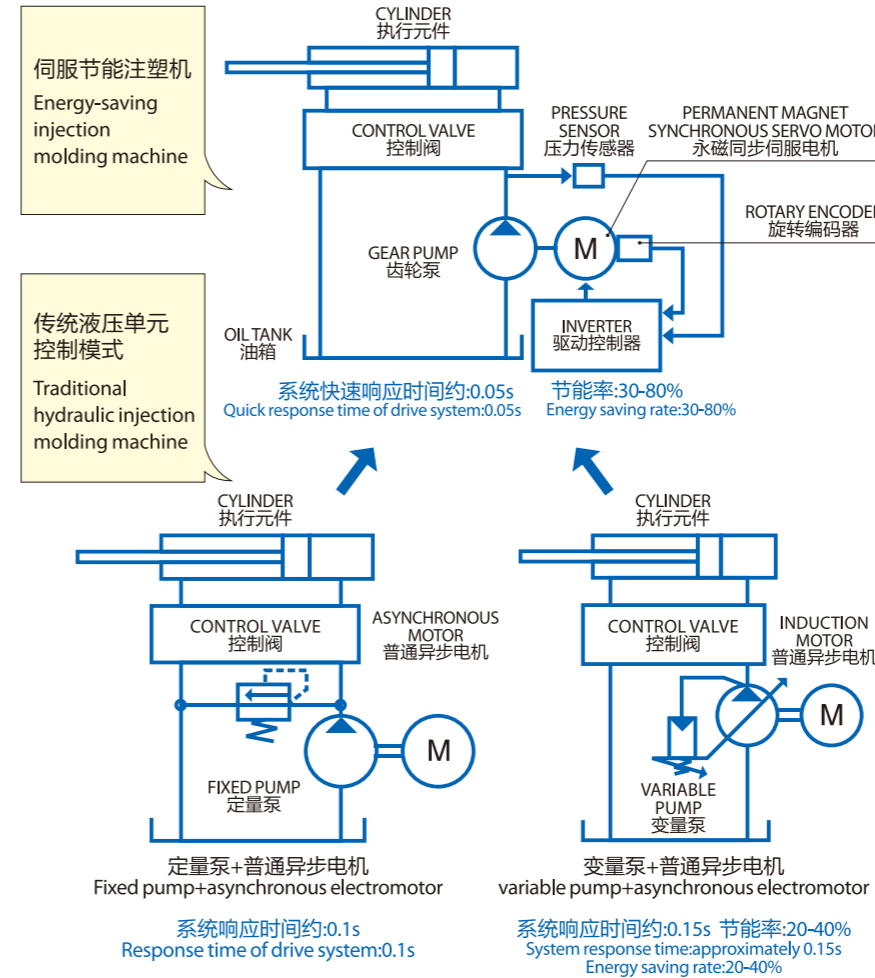
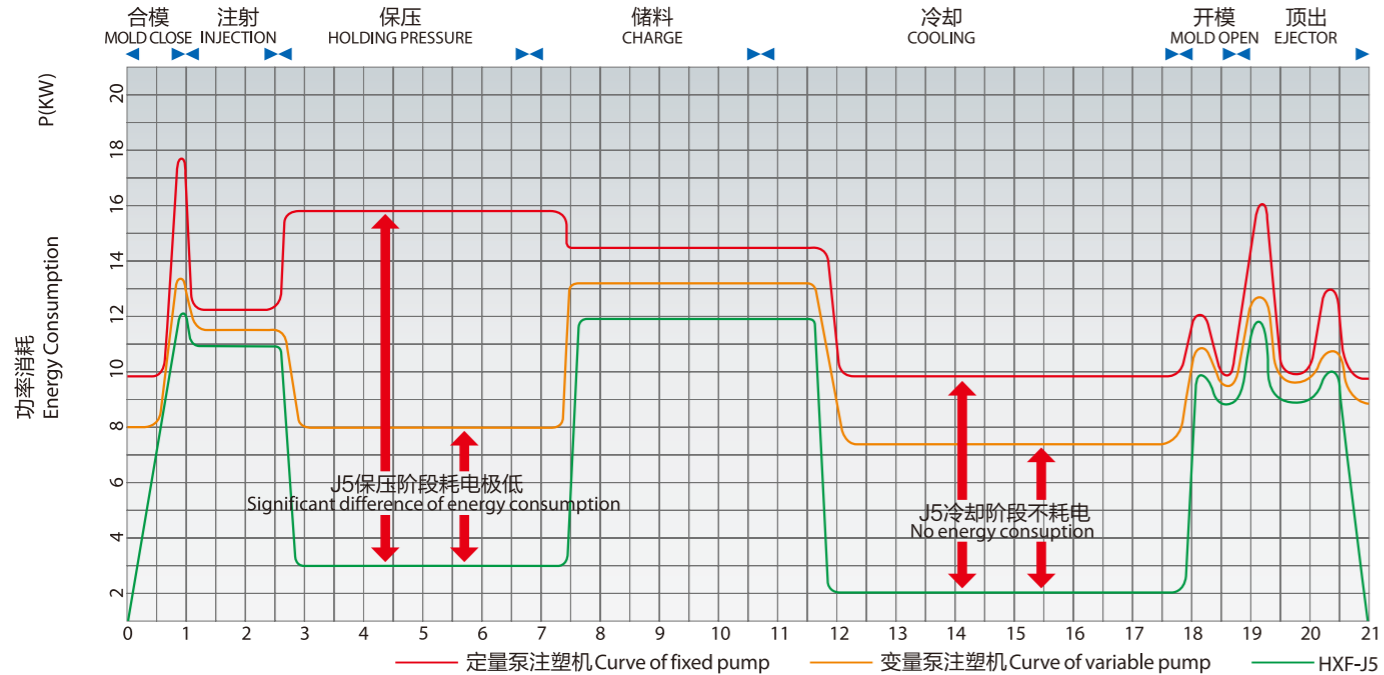

### 高性能的 伺服电动机动力系统 High-capability servo Motor dynamical Control system-precise

伺服节能注塑机，配置旋转编码器和压力传感器，时刻对流量和压力进行反馈，及时通过改变伺服同步永磁电机的旋转和转矩而对流量压力作出相应调整，确保成型重复精度更高，实现节能最大化的要求，最大限度地提高生产效率。

Equipped with a rotary encoder and pressure sensor, the pressure flow state of the energy saving HXF-J5 machine will be transmitted to the controller, the command of which will be sent out to the efficient synchronous servo motor to change the rotation and the torque accordingly. The corresponding flow and pressure adjustment ensures the highest quality and precision of the plastic parts produced, with energy savings and fast response times.

### BETTER MOLDING STABILITY

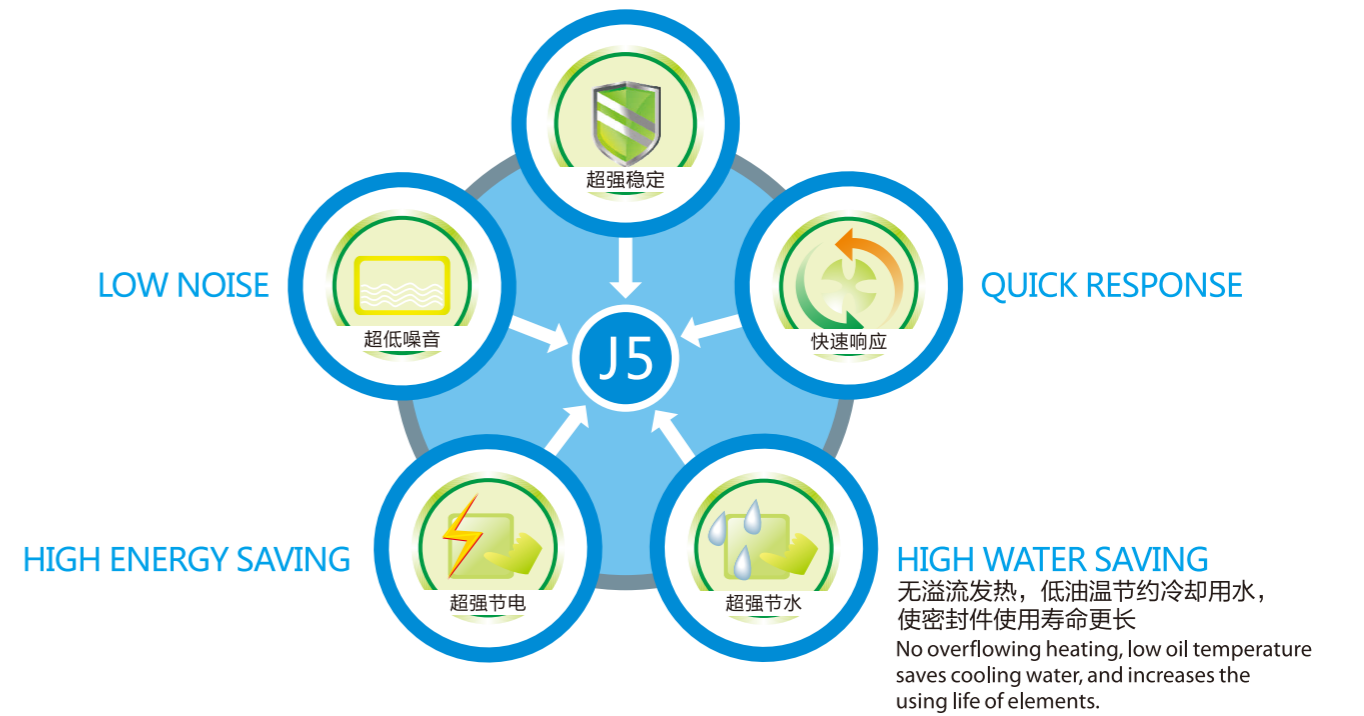

## HXF Series High Speed Injection Molding Machine For Package

# HXF系列高速包装专用注塑机



### HXF270H 高速包装专用注塑机

HXF系列高速包装专用注塑机，针对塑料包装类产品的成型而设计。适合瓶盖、快餐盒及其他薄壁包装类容器等产品的高速注射成型。技术先进，设计合理，运行可靠。连续生产成型周期缩短。

HXF series, specially designed and developed high-speed machine for molding of packaging products such as caps, fast food containers and other thin-wall products.

Advanced technology, reasonable design and reliable performance with short molding cycle time.

## HXF-D Series Two-Component Injection Molding Machine

# HXF-D系列混双色注塑机



### HXF128D 混双色注塑机

HXF-D系列混双色塑料注射成型机，针对双色饰品、工艺品的加工工艺要求，采用左右双位双料管组（双塑化系统）设计；可实现不同物料同时塑化，并在前法兰处均匀混合，在注射时实现产品均匀混色效果；具有混色效果好，注射平稳等优点。

HXF-D series Two-Component injection machine aims at the technological requirements for double-color decoration and arts and crafts and adopts main and assistant double-position dual screw and barrel unit (double plastification system), which may realize simultaneous plastification of different materials, uniform mixing at the front flange and achieve even color mixing effect during injection. The machine enjoys the advantages of good color mixing effect and balanced injection.

# HXF-BMC Series-BMC Injection Molding Machine HXF-BMC系列- BMC专用射出成型机

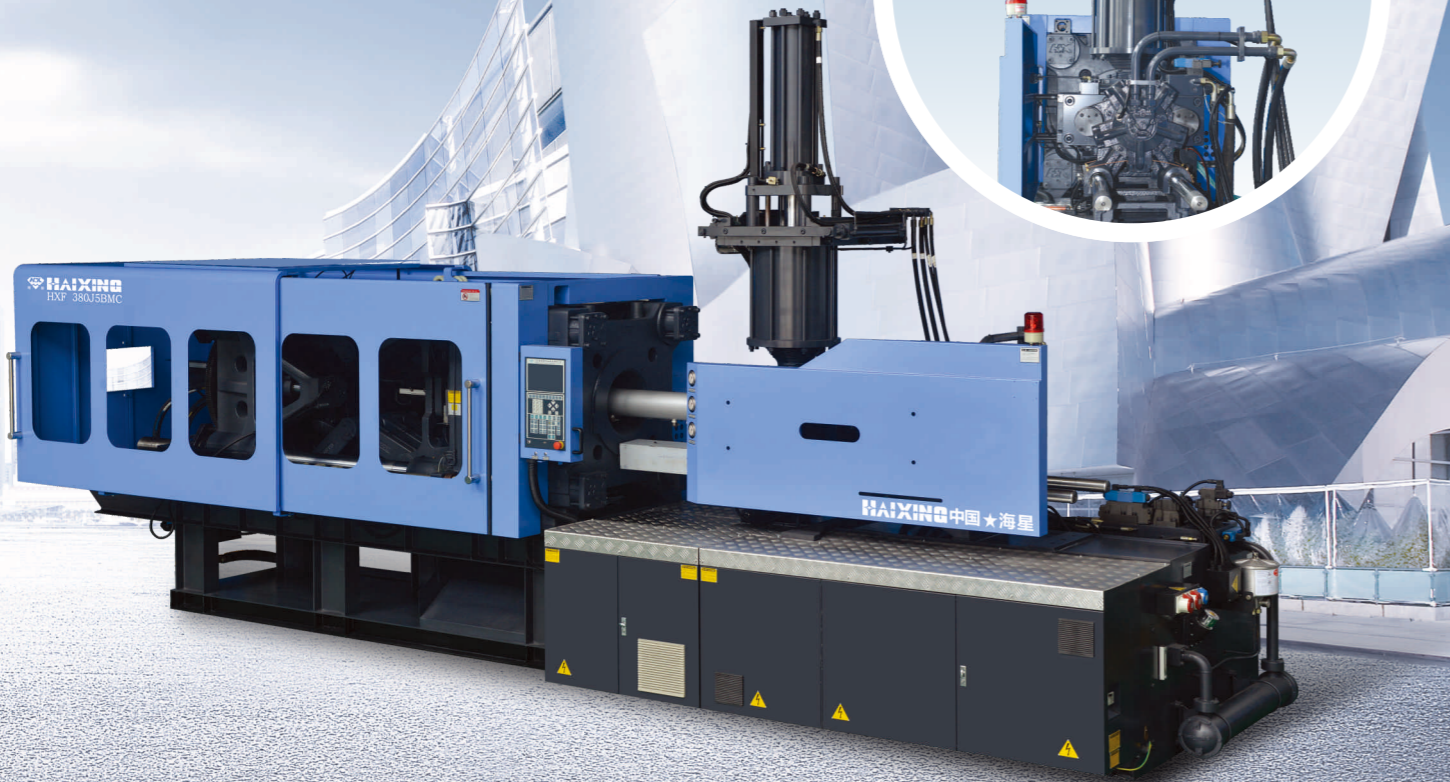

## BMC 专用射出成型机

BMC属于热固性塑料的一种，具有耐高温、耐燃性、耐蚀性、高机械强度、尺寸安定、电器绝缘等特性。可应用于汽车类零件、电子工业、家用电器及通讯器材的外壳及零件。

### 本机特点

采用单缸油压式自动供料装置，可提供稳定的进料功能。

具有填料台设计，塑料补充作业更方便。专用隔热垫板，模温控制更准确。

BMC (Bulk Molding Compounds) is one of the thermosetting plastic material.

BMC has many properties including Heat-resistance, Flame-retardant, Erosion-resistance, High Mechanical Strength, Dimensions Stability and Electrical Insulated. It is widely used into kinds of industries including Automotive parts, Electronic parts, Household appliances and Communication equipment.

### Features

Single cylinder hydraulic auto-feed mechanism, it can supply the function of feeding steady.

Designing filling material stand, it is convenient to fill material. The plate equipped with adiabatic spacer, it can let mold temperature control more precise.

# HXF-G Series Thermosetting Injection Molding Machine HXF-G系列电木专用机



## HXF380G 电木专用机

HXF-G电木专用机配备优化设计的热固性塑料专用料管组，具有塑化效果好，耐用性好；采用名牌模温机对料管组加热，温控准确；锁模部分加装隔热板和辅助模板，并备有模具加热接口，模具温度实现电脑PID控制，精确度高。可胜任电木、电玉等热固性塑料的生产，在此基础上海星公司更可以向客户提供专业的BMC特殊注塑机。

HXF-G Thermosetting Injection Molding Machine is equipped with special screw and barrel unit with optimized design for thermosetting material. It has good plastification effect and durability. Famous brand mould temperature controller is used to heat the screw and barrel unit with accurate temperature control. The clamping unit is equipped with insulating board and auxiliary die plate and provided with mold heating interface. The mold temperature has realized PID control with high accuracy. Special design of nozzle for quick-clearing purpose when machines suspended. The machine can be used for production of thermosetting material such as bakelite. We can make special Thermosetting Injection Molding Machine for BMC material.

## 电木机系列技术规格参数表 Specifications

说明 项目	DESCRIPTION Item	UNIT	HXF88G		HXF128G		HXF160G		HXF220G		HXF260G		HXF320G		HXF380G		HXF470G		
			A	B	A	B	A	B	A	B	A	B	A	B	A	B	A	B	
<b>注射装置</b>			<b>INJECTION UNIT</b>																
螺杆直径	Screw diameter	mm	35	37	37	40	40	45	45	50	50	55	60	65	65	70	75	80	
螺杆长径比	Screw L/D ratio	L/D	20.6	19.5	21.1	19.6	22.5	20	22.2	20	22.5	20.5	21.7	20	22.4	20.6	21.4	20	
理论注射容量	Shot Volume(Theoretical)	cm <sup>3</sup>	123	137	172	201	270	342	334	412	490	593	727	853	1094	1269	1722	1959	
注射重量	Shot weight	g / (克)	148	164	206	241	324	410	401	494	588	712	872	1024	1313	1523	2066	2351	
	(PS)	oz (盎司)	5.2	5.8	7.3	8.5	11.4	14.5	14.1	17.4	20.7	25.1	30.8	36.1	46.3	53.7	72.9	82.9	
注射压力	Injection pressure	Mpa	193	173	196	168	201	159	216	175	205	169	213	182	208	180	177	156	
注射速度	Injection Speed	mm/s	88	100	112	130	122	139	120	148	167	200	238	279	317	369	426	485	
注射行程	Injection Stroke	mm	14	16.8	15.7	20.4	22.8	31.7	26.2	31.5	31.5	41.2	45.5	55.8	57.5	64.3	59.8	68	
螺杆转速	Screw speed	rpm	220		220		180		180		180		180		180		160		
<b>合模装置</b>			<b>CLAMPING UNIT</b>																
合模力	Clamping force	KN	880		1280		1600		2200		2600		3200		3800		4700		
移模行程	Toggle Stroke	mm	320		365		445		490		540		640		700		780		
拉杆间距	Space between tie bars	mm	365 × 365		412 × 412		470 × 470		530 × 530		580 × 580		685 × 685		726 × 726		800 × 800		
最大模厚	Max.Mould Height	mm	380		450		520		560		610		690		760		830		
最小模厚	Min.Mould Height	mm	150		160		180		200		220		250		250		300		
顶出行程	Ejector Stroke	mm	100		130		140		140		150		160		180		200		
顶出力	Ejector Force	KN	27.5		39.6		39.6		62		62		70		110		110		
顶出杆根数	Ejector Number	n	5		5		5		9		9		13		13		17		
<b>其它</b>			<b>OTHERS</b>																
最大油泵压力	Max.Pump Pressure	Mpa	16		16		16		16		16		16		16		16		
油泵功率	Pump Motor Power	KW	11		13		15		18.5		22		30		37		45		
温度控制器	Temperature Controller	KW	(0-400°C) × 2		(0-400°C) × 2		(0-400°C) × 2		(0-400°C) × 2		(0-400°C) × 2		(0-400°C) × 2		(0-400°C) × 2		(0-400°C) × 2		
外型尺寸	Machine Dimensions(L × W × H)	m	3.92 × 1.08 × 2.04		4.39 × 1.14 × 2.08		4.98 × 1.26 × 2.22		5.8 × 1.4 × 2.22		6.04 × 1.49 × 2.34		6.76 × 1.71 × 2.42		7.23 × 1.86 × 2.57		8.00 × 1.90 × 2.71		
油箱容积	Oil Tank Capacity	Liter	200		205		245		320		405		550		650		660		
机器重量	Machine weight	Ton	3.5		4.35		5.65		7.1		8.5		13.2		15		19		

注意:1.正常情况下改善技术参数,不予另行通知。2.除了上述表格中技术规格参数以外,尚需更详细的资料请垂询。

# HXF-V Variable Displacement Pump Injection Molding Machine HXF-V比例变量泵节能注塑机

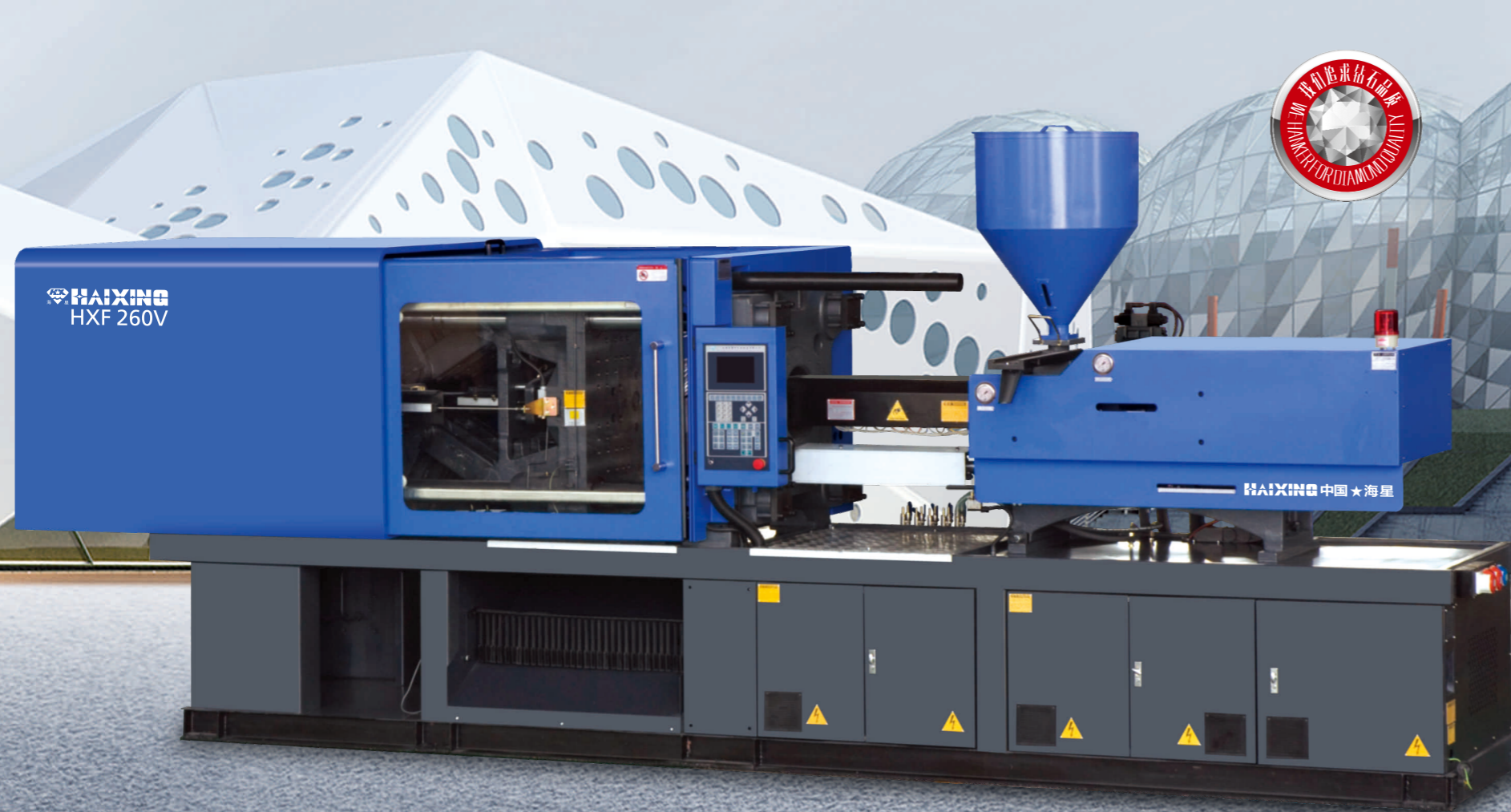

请访问: [www.china-haixing.com](http://www.china-haixing.com) 海星机械中国站点, 您可以获得更多产品、技术资讯。  
相关的解决方案您可以电邮给我们的客户服务中心: [sales@china-haixing.com](mailto:sales@china-haixing.com) 或者致电: 086-574-8836 8836 咨询。  
感谢您对我们公司的产品的了解和支持, 请您留下准确的联系方式, 我们将会安排针对您的客户服务人员进行接洽。

## HXF-260V V比例变量泵节能注塑机

HXF-V系列变量泵注塑机, 配备高响应功率匹配比例变量泵系统令注塑机液压系统输出与整机运行所需功率匹配, 无高压节流溢流能量损失, 与标准机型相比, 可节电20-40%, 成本效益至为明显, 相同电机功率可配用更大排量油泵, 令整机速度加快。更配有进口高性能精密滤油装置, 在该装置正常连续工作情况下, 油污等级达至美国NAS8级以内, 对机器液压系统将无需顾虑。

HXF-V is a new series of Haixing company, the variable displacement pump makes the hydraulic output power always matches with the system requirement. No extra-energy lost via the overflow valve. Comparing with traditional machines, energy saving efficient is around 20%-40% which causes cost reduction obviously.

## 超越价值 满足全方位需求

作为中国塑料机械行业高性能产品及应用解决方案的提供者, 海星积极顺应先进科技带来产业变革, 充分吸收与转化技术的发展成就, 持续创新, 为满足用户的独特需求而推出了多系统的技术解决方案与服务。

对于海星来说, 我们的目标就是创造能解决问题的工具使客户能更大程度地盈利。

为客户创造利润的前提, 首先是为客户开发设计充分满足实际需求的产品。

海星在技术领域不断突破的同时, 更关注产品在不同行业中的实际上应用, 通过与各行业的技术交流, 充分把握不同行业的实际需求, 设计针对性产品及系统解决方案。海星众多针对性产品系列的推出, 受到了行业客户一致赞誉。

有针对性的产品更要有优越的产品品质。

品质来自严谨的科学方法、广泛的研究、高品质管理及专业化的生产, 海星一直坚持上述观念并以作为企业口号的首要部分。努力将质量管理意识落实到产品加工的每一个环节, 从而持续提升产品品质。

# 技术规格参数表 Specifications



说明	DESCRIPTION	UNIT	HXF58			HXF88			HXF128			HXF160			HXF220		
项目	Item		A	B	C	A	B	C	A	B	C	A	B	C	A	B	C
<b>注射装置</b>			<b>INJECTION UNIT</b>														
螺杆直径	Screw diameter	mm	26	30	34	35	37	40	37	40	43	40	45	48	45	50	55
螺杆长径比	Screw L/D ratio	L/D	24	21	19	20.6	19.5	18	21.1	19.6	18.2	22.5	20	18.8	22.2	20	18.2
理论注射容量	Shot Volume(Theoretical)	cm <sup>3</sup>	66	88	113	125	135	158	183	214	247	270	342	389	350	432	522
注射重量	Shot weight	g / ( 克 ) oz ( 盎司 )	60	80	103	109	122	142	164	192	222	243	308	350	315	389	470
注射压力	Injection pressure	Mpa	245	184	143	193	173	148	196	168	145	215	169	149	210	170	141
注射速度	Injection Speed	mm/s		120			93			99			103			96	
注射行程	Injection Stroke	mm		125			126			170			215			220	
螺杆转速	Screw speed	rpm		0~220			0~220			0~200			0~200			0~200	
<b>合模装置</b>			<b>CLAMPING UNIT</b>														
合模力	Clamping force	KN		580			880			1280			1600			2200	
移模行程	Toggle Stroke	mm		270			320			365			445			490	
拉杆间距	Space between tie bars	mm		310×310			365×365			412×412			470×470			530×530	
模板正面尺寸	Platen dimensions(H×V)	mm		480×470			545×545			615×615			691×691			791×791	
最大模厚	Max.Mould Height	mm		320			380			450			520			560	
最小模厚	Min.Mould Height	mm		120			150			160			180			200	
顶出行程	Ejector Stroke	mm		70			100			130			140			140	
顶出力	Ejector Force	KN		22			27.5			39.6			39.6			62	
顶出杆根数	Ejector Number	n		1			5			5			5			9	
<b>其它</b>			<b>OTHERS</b>														
最大油泵压力	Max.Pump Pressure	Mpa		17.5			16			16			16			16	
油泵电机功率	Pump Motor Power	KW		7.5			11			13			15			18.5	
电热功率	Heater Power	KW		7.1			7.9			9.5			14			16.25	
外型尺寸	Machine Dimensions(L×W×H)	m		3.9×1.04×1.78			4.05×1.14×1.94			4.5×1.2×2.0			4.9×1.27×2.16			5.5×1.32×2.24	
油箱容积	Oil Tank Capacity	Liter		160			200			250			300			360	
机器重量	Machine weight	Ton		2.5			3.5			4.35			5.65			7.1	

模板正面尺寸  
PLATEN DIMENSIONS

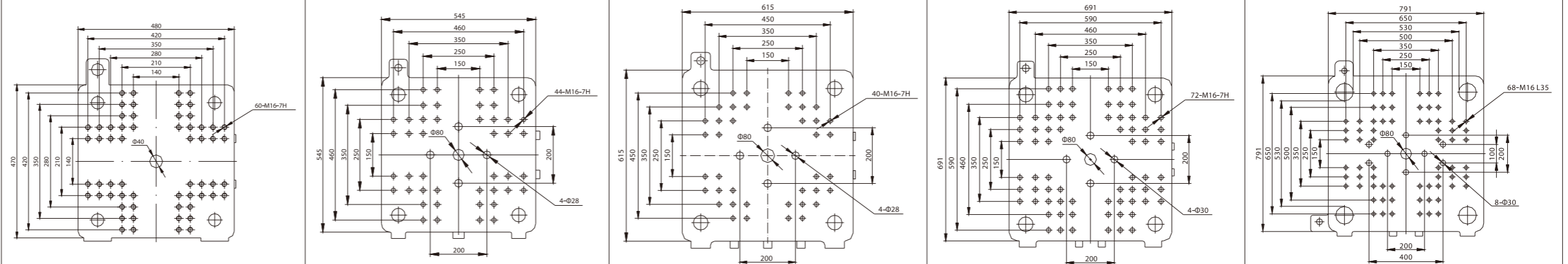

模板侧面尺寸  
PLATEN DIMENSIONS

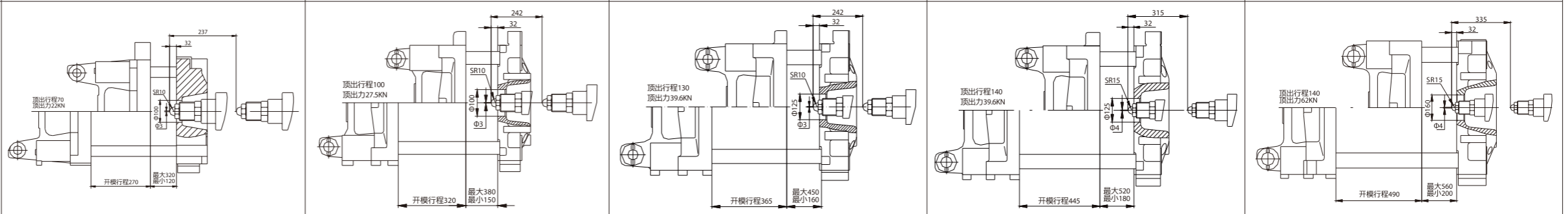

外型尺寸  
MACHINE DIMENSIONS

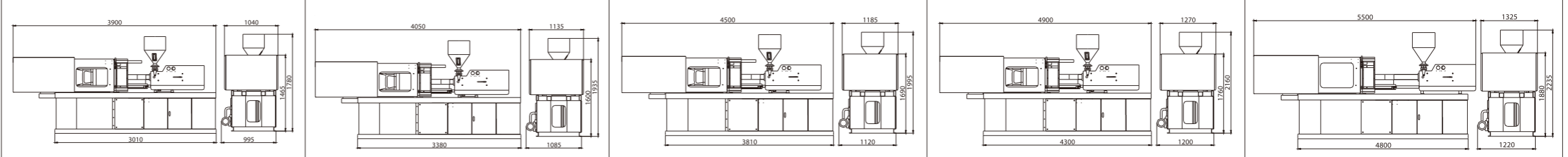

注意:1.正常情况下改善技术参数,不予另行通知。2.除了上述表格中技术规格参数以外,尚需更详细的资料请垂询。



# 技术规格参数表 Specifications



说明	DESCRIPTION	UNIT	HXF260			HXF320			HXF380			HXF470			HXF570			
项目	Item		A	B	C	A	B	C	A	B	C	A	B	C	A	B	C	D
<b>注射装置 INJECTION UNIT</b>																		
螺杆直径	Screw diameter	mm	50	55	60	60	65	70	65	70	75	75	80	84	75	84	90	100
螺杆长径比	Screw L/D ratio	L/D	22.5	20.5	18.8	21.7	20	18.6	22.4	20.6	19.2	21.4	20	19	23.6	21.1	19.7	17.7
理论注射容量	Shot Volume(Theoretical)	cm <sup>3</sup>	491	594	707	735	862	1000	1094	1269	1457	1722	1959	2160	1987	2492	2861	3532
注射重量	Shot weight	g / (克)	442	534	636	661	776	900	985	1142	1311	1550	1763	1944	1788	2242	2575	3179
	(PS)	oz (盎司)	15.6	18.8	22.4	23.3	27.3	31.7	34.7	40.3	46.3	54.7	62.2	68.6	63.1	79.1	90.8	112.1
注射压力	Injection pressure	Mpa	205	169	142	219	187	161	208	180	156	177	156	141	205	163	142	115
注射速度	Injection Speed	mm/s	91			86			92			96			90			
注射行程	Injection Stroke	mm	250			260			330			390			450			
螺杆转速	Screw speed	rpm	0~180			0~180			0~180			0~160			0~110			
<b>合模装置 CLAMPING UNIT</b>																		
合模力	Clamping force	KN	2600			3200			3800			4700			5700			
移模行程	Toggle Stroke	mm	540			640			700			780			850			
拉杆间距	Space between tie bars	mm	580×580			685×685			726×726			820×800			835×835			
模板正面尺寸	Platen dimensions(H×V)	mm	860×860			990×990			1036×1040			1210×1180			1240×1250			
最大模厚	Max.Mould Height	mm	610			690			760			830			880			
最小模厚	Min.Mould Height	mm	220			250			250			300			350			
顶出行程	Ejector Stroke	mm	150			160			180			200			250			
顶出力	Ejector Force	KN	62			70			110			120			158			
顶出杆根数	Ejector Number	n	9			13			13			17			17			
<b>其它 OTHERS</b>																		
最大油泵压力	Max.Pump Pressure	Mpa	16			16			16			16			16			
油泵电机功率	Pump Motor Power	KW	22			30			37			45			55			
电热功率	Heater Power	KW	17.3			24.2			26			32.5			36.9			
外型尺寸	Machine Dimensions(L×W×H)	m	5.93×1.4×2.32			6.88×1.77×2.43			7.36×1.88×2.62			7.92×1.97×2.69			8.82×2.32×2.80			
油箱容积	Oil Tank Capacity	Liter	405			600			700			800			1000			
机器重量	Machine weight	Ton	8.5			13.2			15			19			27			

模板正面尺寸  
PLATEN DIMENSIONS

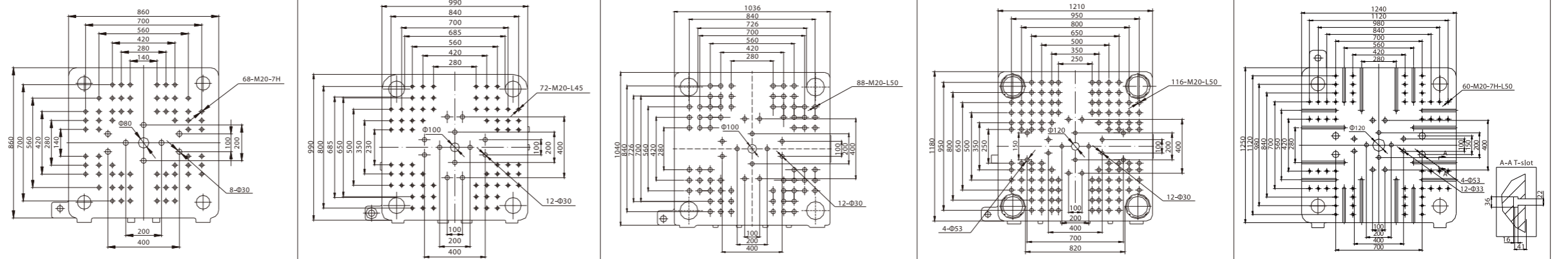

模板侧面尺寸  
PLATEN DIMENSIONS

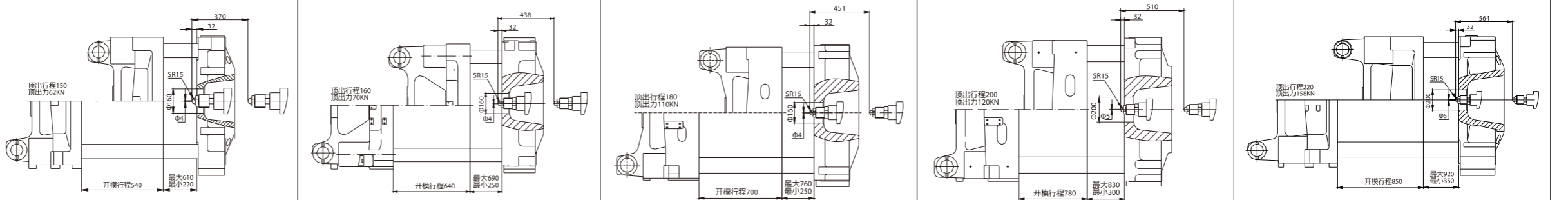

外型尺寸  
MACHINE DIMENSIONS

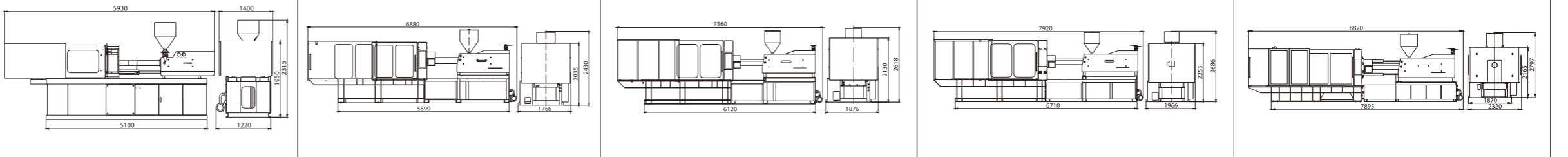

注意:1.正常情况下改善技术参数,不予另行通知。2.除了上述表格中技术规格参数以外,尚需更详细的资料请垂询。

# 技术规格参数表 Specifications



说明	DESCRIPTION	UNIT	HXF650				HXF800				HXF1000				HXF1300			
项目	Item		A	B	C	D	A	B	C	D	A	B	C	D	A	B	C	D
<b>注射装置</b>	<b>INJECTION UNIT</b>																	
螺杆直径	Screw diameter	mm	80	90	100	110	90	100	110	120	100	110	120	130	110	120	130	140
螺杆长径比	Screw L/D ratio	L/D	24.8	22	19.8	18	24.5	22	20	18.3	24.3	22.1	20.2	18.7	26.2	24.1	22.4	20.9
理论注射容量	Shot Volume(Theoretical)	cm <sup>3</sup>	2261	2861	3533	4274	2925	3611	4369	5200	4004	4844	5765	6766	5224	6217	7297	8462
注射重量	Shot weight	g / ( 克 )	2035	2575	3179	3847	2632	3250	3932	4680	3603	4360	5189	6089	4702	5595	6567	7616
	(PS)	oz ( 盎司 )	71.8	90.8	112.1	135.7	92.9	114.6	138.7	165.1	127.1	153.8	183	214.8	165.8	197.4	231.6	268.6
注射压力	Injection pressure	Mpa	224	177	143	118	228	184	152	128	211	174	146	125	205	172	147	126
注射速度	Injection Speed	mm/s	95				88				91				84			
注射行程	Injection Stroke	mm	450				460				510				550			
螺杆转速	Screw speed	rpm	0~110				0~110				0~107				0~91			
<b>合模装置</b>	<b>CLAMPING UNIT</b>																	
合模力	Clamping force	KN	6500				8000				10000				13000			
移模行程	Toggle Stroke	mm	900				1040				1200				1400			
拉杆间距	Space between tie bars	mm	900×900				1000×1000				1120×1120				1350×1280			
模板正面尺寸	Platen dimensions(H×V)	mm	1350×1400				1465×1480				1680×1780				1934×1896			
最大模厚	Max.Mould Height	mm	900				1030				1200				1400			
最小模厚	Min.Mould Height	mm	400				400				500				550			
顶出行程	Ejector Stroke	mm	260				280				320				350			
顶出力	Ejector Force	KN	186				186				215				215			
顶出杆根数	Ejector Number	n	17				21				21				25			
<b>其它</b>	<b>OTHERS</b>																	
最大油泵压力	Max.Pump Pressure	Mpa	16				16				16				16			
油泵电机功率	Pump Motor Power	KW	30+30				37+37				45+45				55+55			
电热功率	Heater Power	KW	50.9				56.1				79.35				84.95			
外型尺寸	Machine Dimensions(L×W×H)	m	9.93×2.45×2.80				11.05×2.65×3.80				12.0×3.0×3.3				13.2×3.1×3.6			
油箱容积	Oil Tank Capacity	Liter	1200				1500				1900				2400			
机器重量	Machine weight	Ton	32				40				55				67			

模板正面尺寸  
PLATEN DIMENSIONS

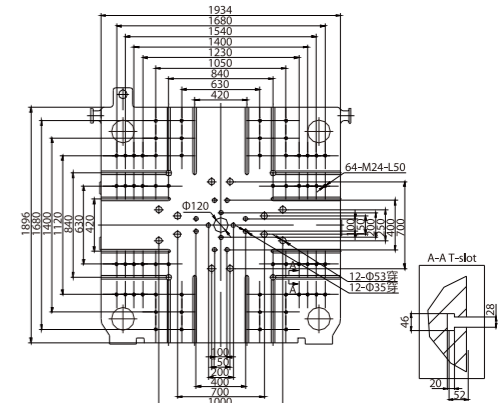
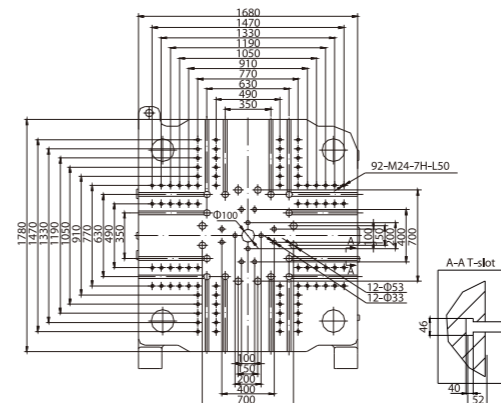
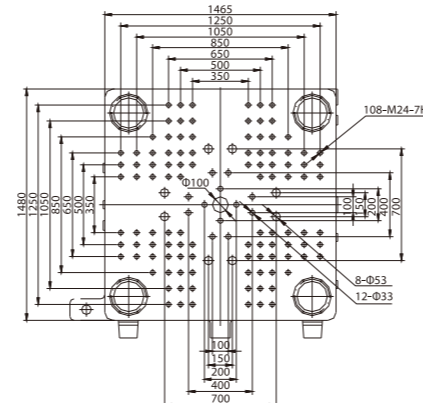
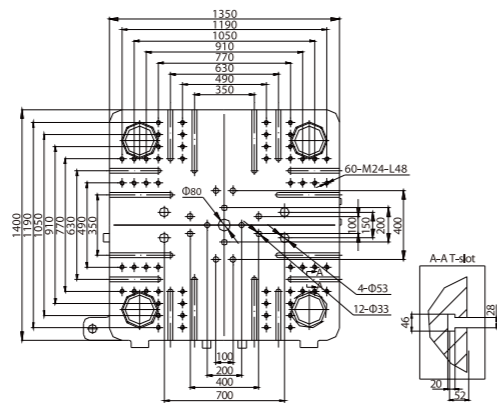

模板侧面尺寸  
PLATEN DIMENSIONS

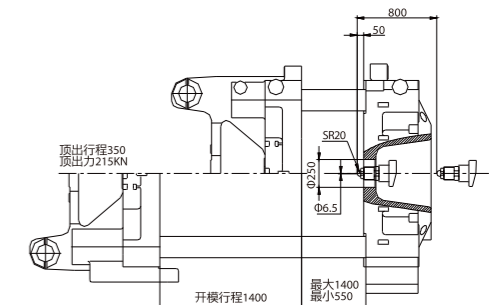
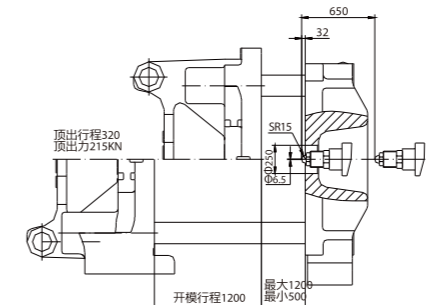
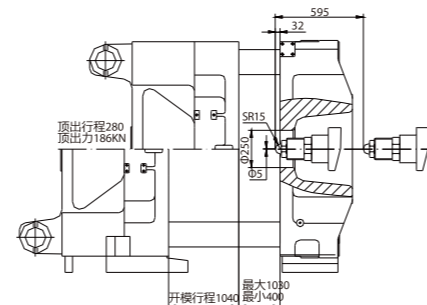
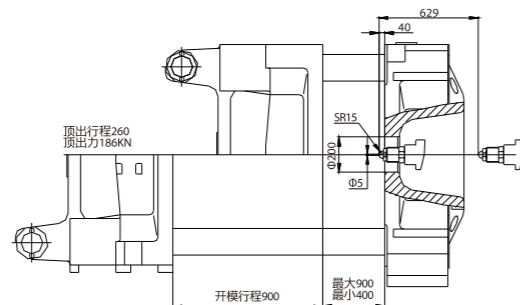

外型尺寸  
MACHINE DIMENSIONS

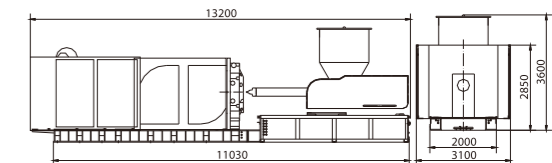
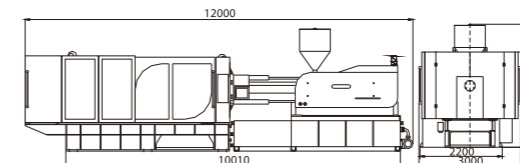
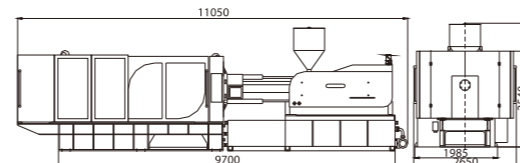
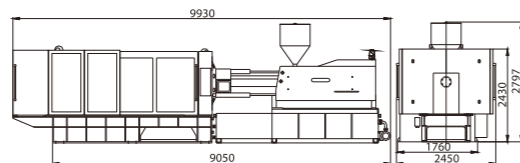

注意:1.正常情况下改善技术参数,不予另行通知。2.除了上述表格中技术规格参数以外,尚需更详细的资料请垂询。

# 技术规格参数表 Specifications



说明	DESCRIPTION	UNIT	HXF1600				HXF2100			HXF2800			HXF3300
项目	Item		A	B	C	D	A	B	C	A	B	C	A
<b>注射装置 INJECTION UNIT</b>													
螺杆直径	Screw diameter	mm	120	130	140	150	140	150	160	170	200	215	215
螺杆长径比	Screw L/D ratio	L/D	26.1	24.1	22.4	20.9	22.4	20.9	19.6	23.5	20	21	21
理论注射容量	Shot Volume(Theoretical)	cm <sup>3</sup>	6669	7827	9078	10421	11084	12723	14476	19293	35154	43530	43530
注射重量	Shot weight	g / (克)	6002	7045	8170	9379	10086	11578	13174	17557	31990	39612	39612
	(PS)	oz (盎司)	211.7	248.5	288.2	330.8	355.8	408.4	464.7	620.4	1130.4	1399.7	1399.7
注射压力	Injection pressure	Mpa	193	164	142	123	163	142	125	161	137	135	135
注射速度	Injection Speed	mm/s	104				95			86.2	73.5	64.3	64.3
注射行程	Injection Stroke	mm	590				720			850	1120	1200	1200
螺杆转速	Screw speed	rpm	0~99				0~80			0~65	0~60	0~50	0~50
<b>合模装置 CLAMPING UNIT</b>													
合模力	Clamping force	KN	16000				21000			28000			33000
移模行程	Toggle Stroke	mm	1600				1800			2000			2150
拉杆间距	Space between tie bars	mm	1500×1415				1750×1600			1900×1750			2160×1900
模板正面尺寸	Platen dimensions(H×V)	mm	2180×2180				2480×2380			2735×2685			3100×3005
最大模厚	Max.Mould Height	mm	1500				1700			1900			1900
最小模厚	Min.Mould Height	mm	700				780			1000			1000
顶出行程	Ejector Stroke	mm	350				400			450			500
顶出力	Ejector Force	KN	318				430			430			550
顶出杆根数	Ejector Number	n	29				29			29			25
<b>其它 OTHERS</b>													
最大油泵压力	Max.Pump Pressure	Mpa	16				16			16			16
油泵电机功率	Pump Motor Power	KW	45+45+45				45+55+55			55×3	45+55×3	55×4	55×4
电热功率	Heater Power	KW	101.85				114.05			170	170	188	188
外型尺寸	Machine Dimensions(L×W×H)	m	13.85×3.43×4.20				16.0×3.6×4.8			19×4×5.5			22×4.5×5.7
油箱容积	Oil Tank Capacity	Liter	2800				3000			4000			4700
机器重量	Machine weight	Ton	105				139			192	197	209	250

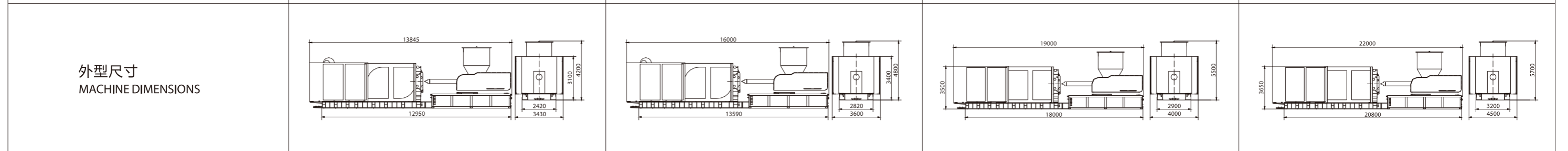
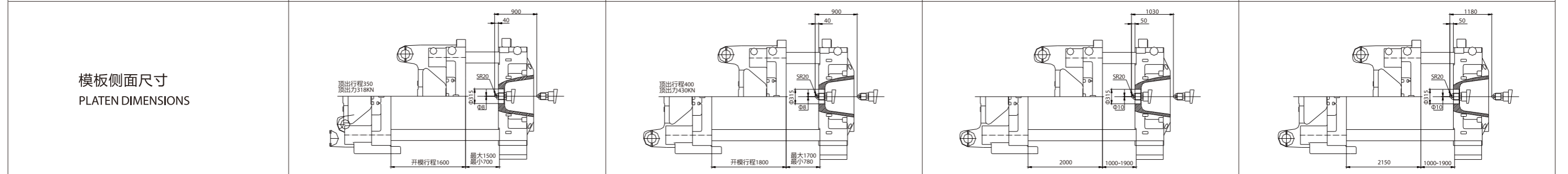
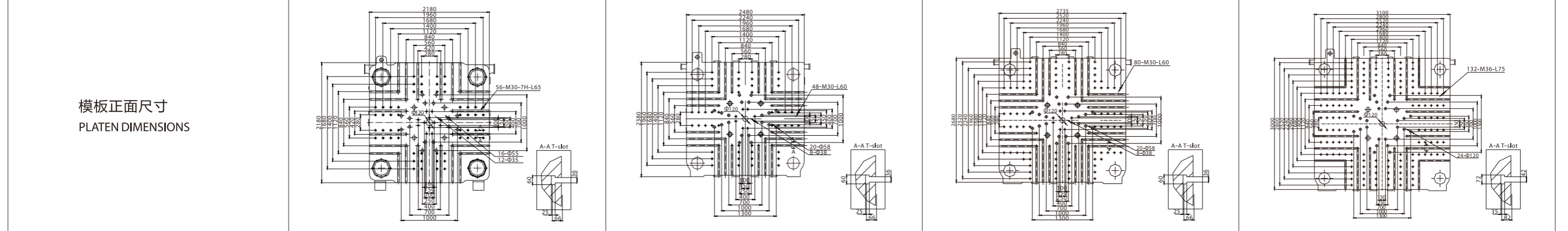

注意:1.正常情况下改善技术参数,不予另行通知。2.除了上述表格中技术规格参数以外,尚需更详细的资料请垂询。

## →→ 标准装置

双缸平衡式注射系统  
多级压力、多级速度射胶调整  
背压调节装置  
差动式高速闭模  
低压模保  
液压单组抽插芯  
多种液压顶出方式  
机械、电气安全装置  
自动润滑系统  
油压安全比例控制  
全电脑控制  
模具记忆系统

## Standard Features

Double-cylinder balance injection system.  
Multi-stage pressure & speed injection.  
Back pressure adjustment device.  
High speed clamping.  
Low pressure mold protection.  
Single hydraulic core pulling and inserting.  
Multiple hydraulic ejector knock-out.  
Mechanical, electrical safety device.  
Auto lubrication system.  
Hydraulic pressure full proportional control.  
All computer control system.  
Molding data memory system.

## →→ 选择装置

液压双组抽插芯  
气顶  
液压旋转脱模  
液压安全保护

## Optional Features

Double hydraulic core pulling and inserting.  
Air blow  
Hydraulic unscrew device  
Hydraulic safety device

## →→ 标准配件

机械防震脚垫  
加长喷嘴  
备用零件  
工具箱

## Standard Accessory

Mechanical leveling pad.  
Extended nozzle.  
Spare parts kit.  
Tool box.

## →→ 选择配件

机械手  
干燥料斗  
自动上料机  
磁力架  
模具压板  
冷水机  
塑料除湿机  
模温控制机  
油温控制器  
旁路滤油器

## Optional Accessory

Robotic pincher  
Hopper dryer  
Auto loader  
Hopper magnet  
Mold clamps  
Water cooler  
Plastic dehumidizer  
Mold temperature controller  
Oil temperature controller  
Oil bypass filter

## Remarks说明

理论注射容量=(注塑机)料筒截面积×螺杆行程  
注射重量为PS理论容量的91%

Theoretical shot volume=(screw cylinder  
cross section) × (screw stroke)  
The injection shot weight should be 91% of  
the theoretical shot volume for  
polystyrene(ps).

## Note注意

当您有成型PC、PA、PMMA、PET、PVC等工程塑料制品的计划,请让我们知道  
正常情况下改善技术规格参数,不予另行通知  
除了上述表格中技术规格参数以外,尚需更详细的资料,请垂询  
产品照片仅供参考,与出售实物略有不同

When PC(polycarbonate), PVC and other plastic material used for engineering are planned  
for molding, it is necessary to inform us for special designation.  
Due to continual improvement, specifications are subject to change without notification.  
There is more detailed documentation for your availability in addition to above specification.  
The machine pictures are for your visual reference, may have trivial difference from the  
actual machines.

CE 本公司可提供CE认证的产品,如欲  
购CE认证的产品则须在合同中阐述。

Machine with CE certification is available,  
please point out in the contract for CE products.

## 特殊订单 Special Orders

## 产生均匀熔化物的UB型螺杆

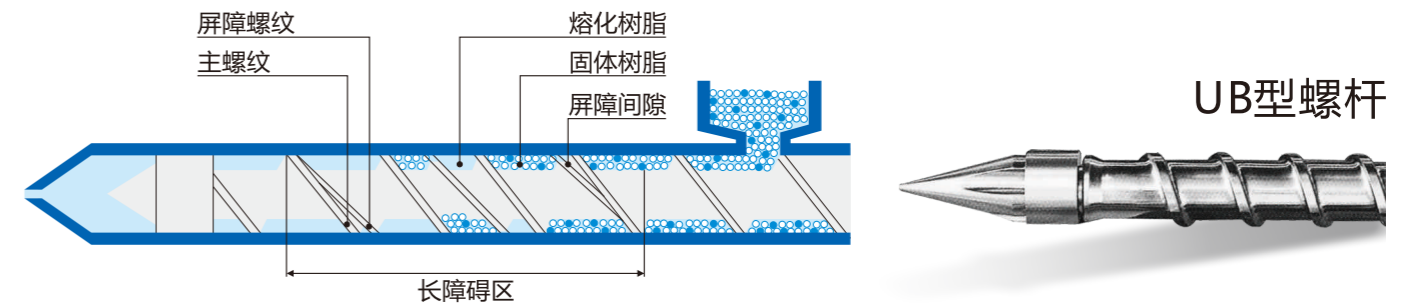

通过屏障螺纹分离固体树脂和熔化树脂,生成均质的熔化物。当树脂通过料筒内壁与屏障螺纹之间的小间隙时,被适当地剪切。

## 提高喷嘴的温度调节精度

采用PID控制,以2秒一个控制周期迅速对应于设定温度的变更及干扰。通过对喷嘴温度进行精密控制,提高成形的稳定性,而且由于采用了SSR(固体继电器)能更长控制回路的工作寿命。

## 可根据客户要求提供各种机器颜色

根据客户对机器颜色的要求,由我公司制作颜色样板,客户对样板确认后,为客户量身定制各种机器颜色,达到人性化要求。

## 螺杆背压控制实现均匀增塑

设置螺杆背压专用的比例阀,实现了均匀增塑及稳定成形。

## 快速射出装置

可提供氮气辅助射胶装置,或同时配合加大排量油泵使注射速率高达400mm/s,对薄壁成型、减少成型品的残存应力、缩短循环时间等很有效。

## 注射速度、压力闭环式控制(选购件)

选择采用了闭环式控制,可以依照检测螺杆移动速度和注射压力的实行值去确切修正油温及负荷的变动、时效变化等,令连续稳定成形更放心。

## 二段合模防止翘曲、收缩

以程序功能分二阶段控制合模压力,实现注射压缩成形。防止成形产品的翘曲、收缩,确保其成形稳定性。



## 海星企业文化 Haixing company culture

# 打造一流的价值共赢平台 To build a first-class value and win-win platform

海星以整合资源、共创价值为己任，致力于个人、企业和社会等资源的完美融合，构建团队和个人共同成长的企业平台，实现个人、企业和社会的价值共赢。  
Haixing in order to integrate resources to create the value of responsibility, the perfect fusion of committed individuals, businesses and social resources, build teams and individuals to the growth of enterprise platform, and achieve the win-win situation of individuals, businesses and social values.

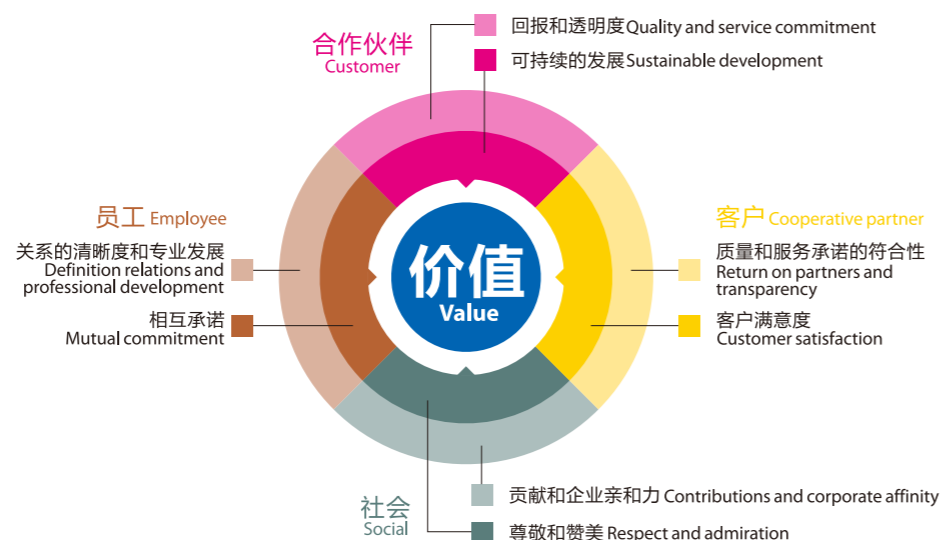

### 为客户创造价值 // Creating value for customers

海星提倡以客户为中心。  
质量：确保我们提供的产品和服务充分满足客户实际需求。  
符合性：严格履行我们的承诺。  
Haixing advocates customers are centre  
Quality: to ensure that the products and services which we provided are fully meet customer's demand.  
Compliance: strictly fulfill our promise.

### 为员工创造机会 // Create opportunities for employees

通过营造“机会-人才-资源-产品-市场-机会”的良性循环。  
清晰度：明确的权利与义务关系，将个人事业与企业发展紧密地联系在一起。  
专业发展：确保为所有员工提供更好的专业发展机会。  
Create a virtuous cycle of "opportunity, talent, resources, products, markets, opportunities".  
Clarity: clear rights and obligations, career and business development are closely linked.  
Professional Development: to provide better professional development opportunities to all our employees.

### 为合作伙伴创造财富 // Create wealth for our partners

最大限度保证合作伙伴的利益。  
透明度：充分的信息共享，共同开拓市场。  
可持续发展：构建不断完善的业务模式和财富平台。  
The maximum to ensure the interests for our partners.  
Transparency: full information sharing, co-development of the market.  
Sustainable Development: Building a continuous improvement business model and wealth platform.

### 为社会创造效益 // Create benefits for society

取之于社会，用之于社会，推动企业与社会和谐发展。  
贡献：创造就业机会、促进经济发展、热心公益事业，建设和谐社会。  
亲和力：致力于成为社会各界广泛信赖和尊敬的企业。  
Take from society and use for society, to promote enterprise and harmonious development of society.  
Contribution: to create jobs and promote economic development, public-spirited career, building a harmonious society.  
Accessibility: to become widely trusted and respected companies of all sectors of society.

## Quality system 品质体系 缜密工作 打造完美品质 Careful work to create the perfect quality

过硬的产品品质是一切之根本，一直以来海星都把品质作为企业的生命，除建立完善的产品质量保证体系外，更重要的是，海星的主要骨干领导都是技术出身，通过他们的言传身教，质量意识已深入员工的心中。品质体系产品质量是企业生存与发展的根本保证海星视产品质量为企业生命，采取高标准的质量管理并持续改进，追求产品质量的完美。质量第一，既是对我们自己的严格要求，更是对客户的承诺与负责。

Excellent product quality are all fundamental, haixing always regard the quality as its life, in addition to establish and improve the product quality system, more importantly, the main department manager of haixing are technical background, through their words and deeds, quality consciousness has penetrated the hearts of the staff. The quality system and product quality are the fundamental guarantee for enterprise's survival and development, haixing regards the product quality as enterprise life, adopt high standards of quality management and continuous improvement, and pursuit of the perfection of product quality. Quality is first, it is not only for our own stringent requirements, but also is responsibility for our customers.

### 持续创新 保证了海星机器行业领先的地位 Continuous innovation To ensure haixing injection machine is the leading position of machine industry

海星本着“做客户想要的机器”的开发理念，采用最现代化的数字设计方式进行设计和验证后，对试加工机进行耐用性能评估测试，设计臻于完美。

The development philosophy of haixing is "make the machine which customer needed".  
Adopt the most modern digital design to design and test the trial processing machine's durable performance evaluation, designed to perfect.

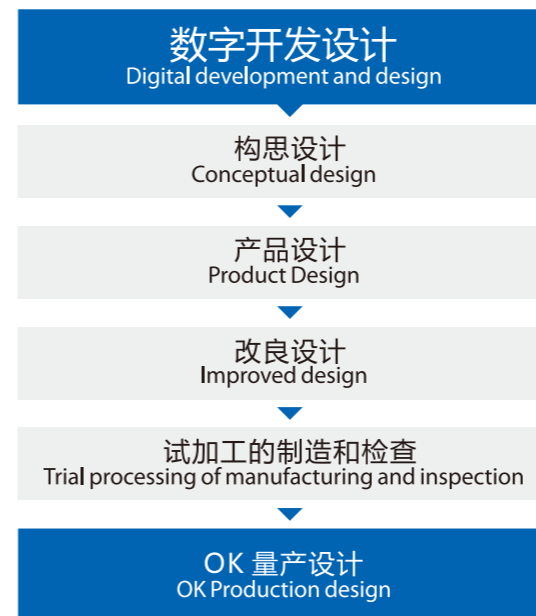

质量始终是企业的生命，海星导入并长期坚持贯彻执行ISO9001国际质量管理体系，以客户目标为导向，从原料配件的采购到加工生产、组装、调试，每一个环节都严格把关，以极限提升产品的各项性能指标。

The quality is always the life of the enterprise, Ningbo Haixing Plastic Machinery Manufacturing Co.,Ltd. lead to and adherence to implement the ISO9001 international quality management system all the time, according to customers' target, accessories from the raw material purchase to processing, assembly, testing, check every step strictly carefull, in order to improve all the performance indicators of the products.

# SALES & MARKETING

